

[54] RECONFIGURABLE TOY VEHICLE

[75] Inventor: Takayoshi Doi, Ichikawa, Japan

[73] Assignee: Takara Co., Ltd., Tokyo, Japan

[**] Term: 14 Years

[21] Appl. No.: 944,591

[22] Filed: Dec. 17, 1986

[30] Foreign Application Priority Data

Oct. 17, 1986 [JP] Japan 61-41442

[52] U.S. Cl. D21/150; D21/136; D21/166

[58] Field of Search D21/150, 128, 136, 166, D21/137-140; D12/86, 88, 96; 446/71-78, 94, 97, 383, 381, 487

[56] References Cited

U.S. PATENT DOCUMENTS

| | | | |
|------------|---------|-----------------|---------|
| D. 279,916 | 7/1985 | Obara | D21/136 |
| D. 281,087 | 10/1985 | Ohno | D21/136 |
| D. 284,491 | 7/1986 | Ohno | D21/150 |
| D. 294,609 | 3/1988 | Matsumoto | D21/136 |
| D. 294,610 | 3/1988 | Matsumoto | D21/136 |
| D. 295,199 | 4/1988 | Yoke | D21/136 |

Primary Examiner—Charles A. Rademaker
 Attorney, Agent, or Firm—Price, Gess, & Ubell

[57] CLAIM

The ornamental design for a reconfigurable toy vehicle, as shown and described.

DESCRIPTION

FIG. 1 is a front perspective view of a reconfigurable toy vehicle showing my new design;
 FIG. 2 is a front elevational view thereof;
 FIG. 3 is a right side elevational view thereof, the side opposite being a mirror image;
 FIG. 4 is a rear elevational view thereof;
 FIG. 5 is a top plan view thereof;
 FIG. 6 is a bottom plan view thereof;
 FIG. 7 is another front perspective view of the design shown in FIGS. 1 through 6 in a humanoid robot configuration;
 FIG. 8 is a front elevational view thereof;
 FIG. 9 is a right side elevational view thereof, the side opposite being a mirror image;
 FIG. 10 is a rear elevational view thereof;
 FIG. 11 is a top plan view thereof;
 FIG. 12 is a bottom plan view thereof;
 FIG. 13 is further front perspective view of the design shown in FIGS. 1 through 12 in another humanoid robot configuration;
 FIG. 14 is a front elevational view thereof;
 FIG. 15 is a right side elevational view thereof, the side opposite being a mirror image;
 FIG. 16 is a rear elevational view thereof;
 FIG. 17 is a top plan view thereof; and
 FIG. 18 is a bottom plan view thereof.

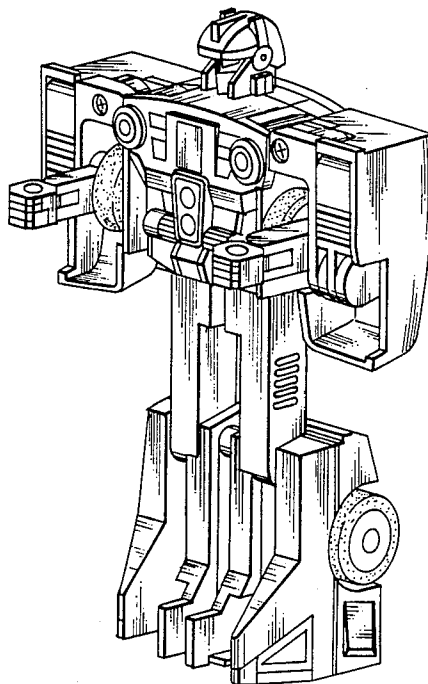
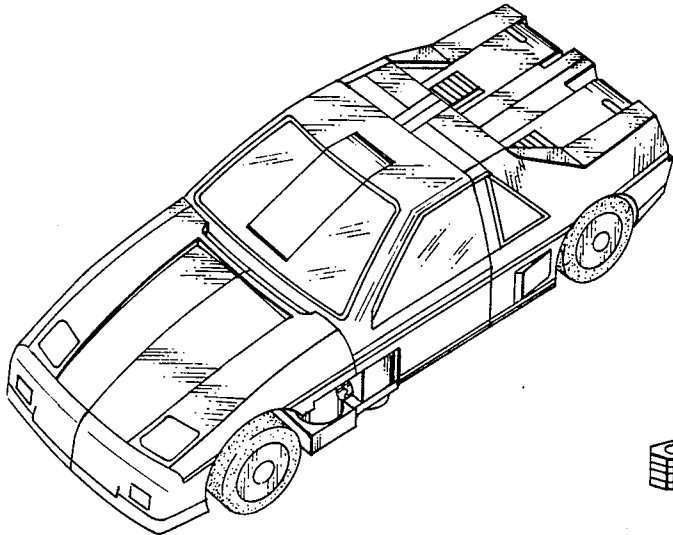

FIG. 1

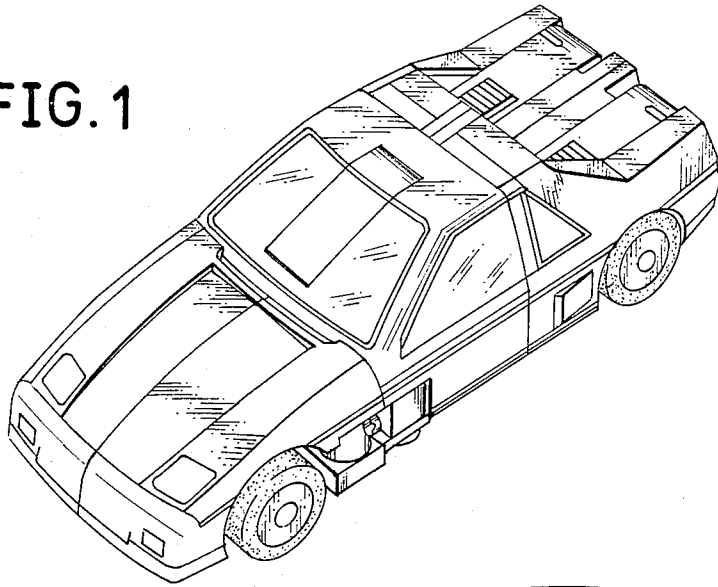

FIG. 2

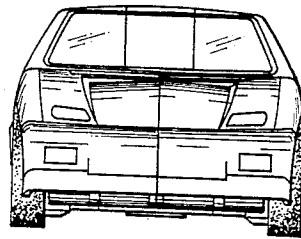

FIG. 3

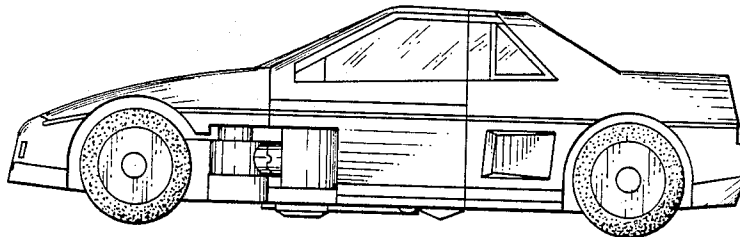

FIG. 6

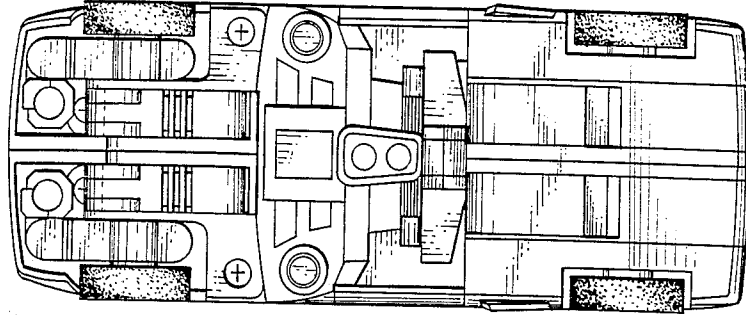

FIG. 5

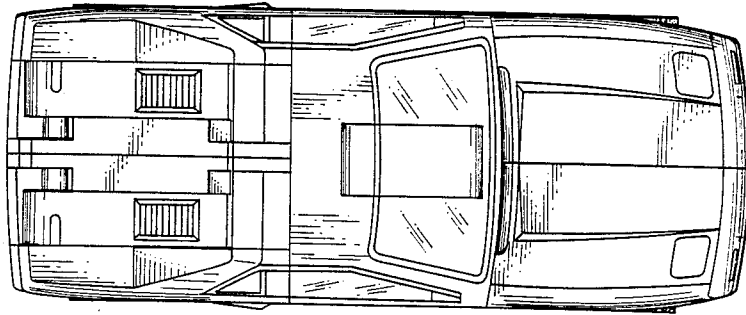
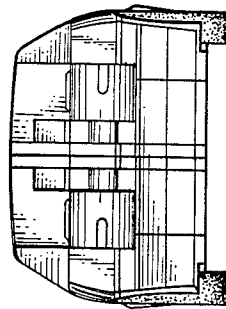

FIG. 4



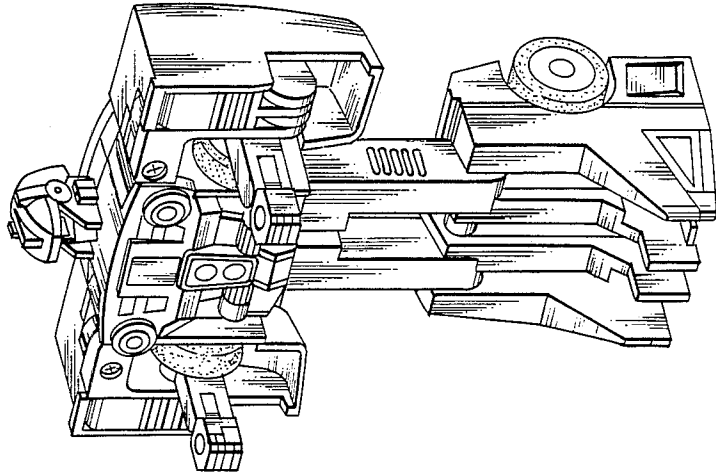

FIG. 7

FIG.9

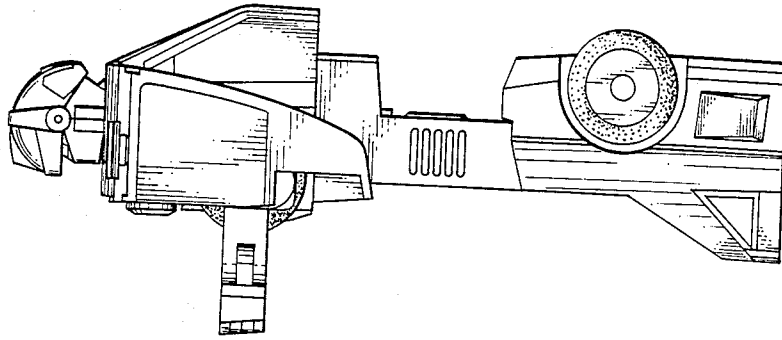

FIG.8

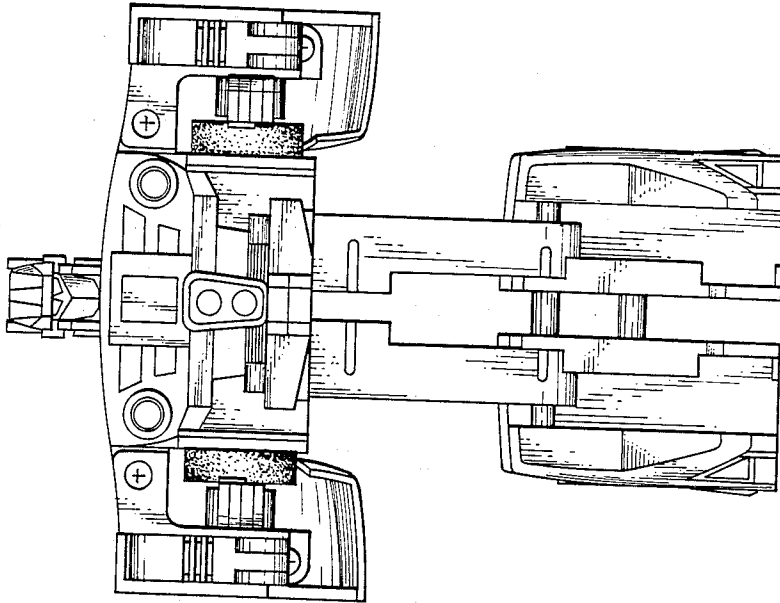

FIG.11

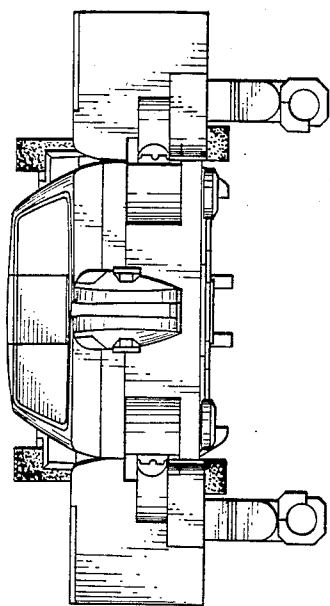
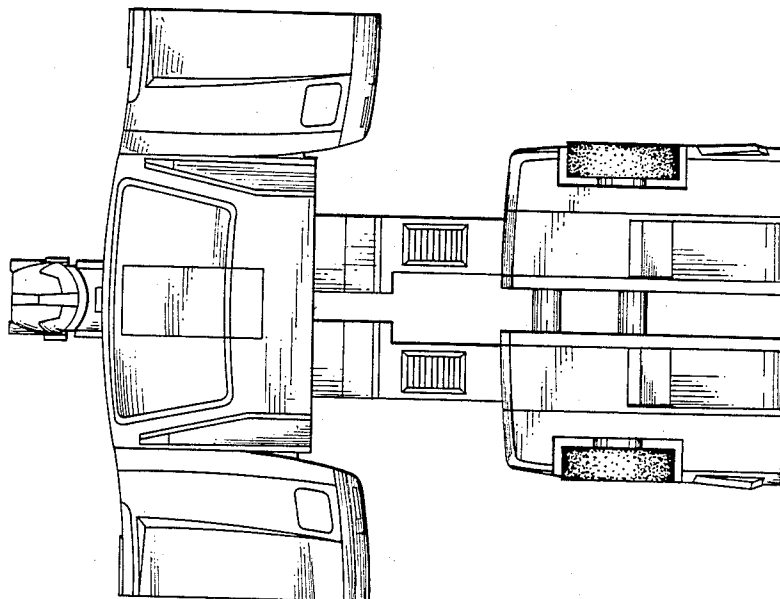

FIG.12



FIG.10



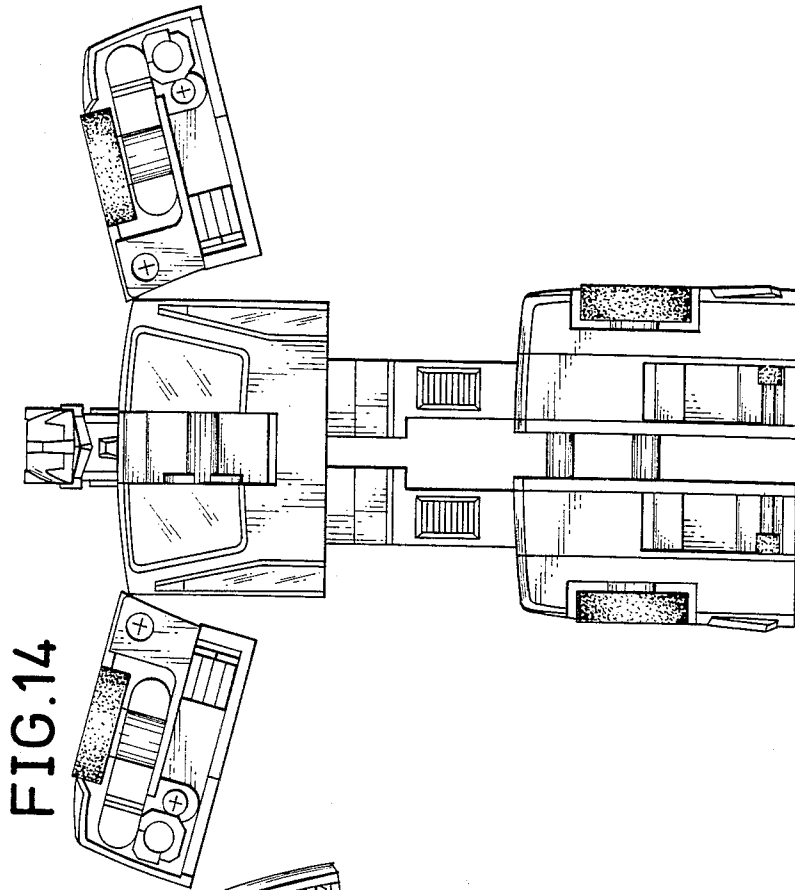

FIG. 14

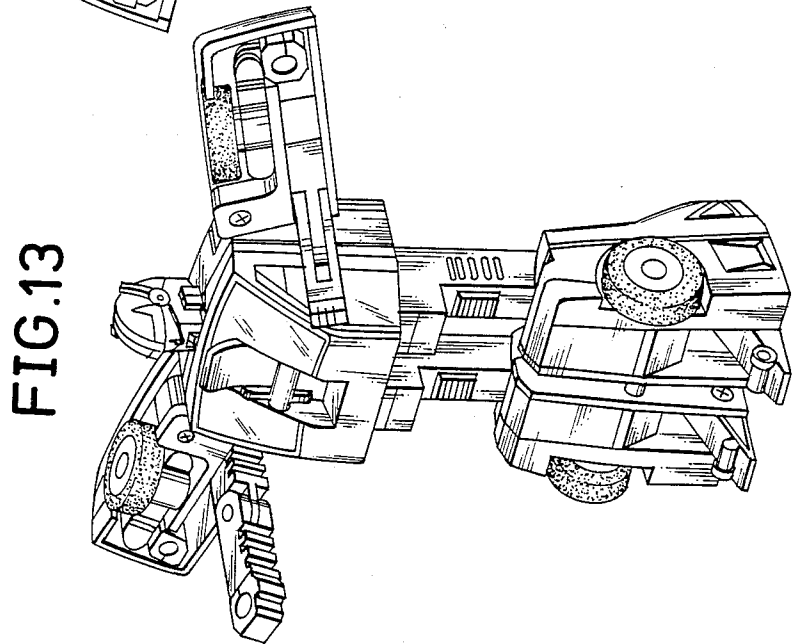

FIG. 13

FIG.16

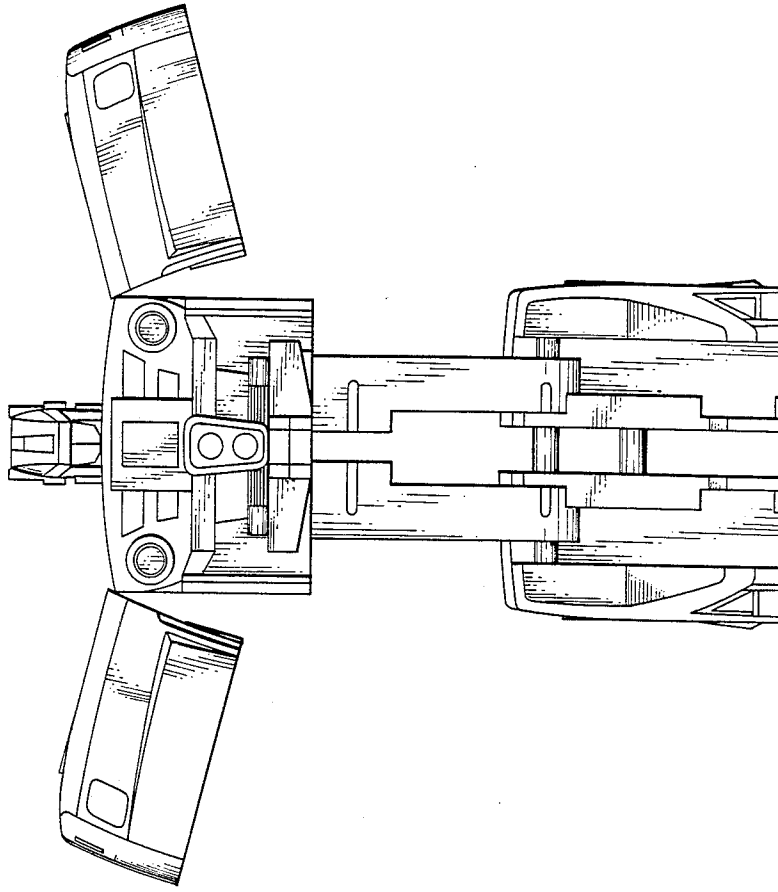
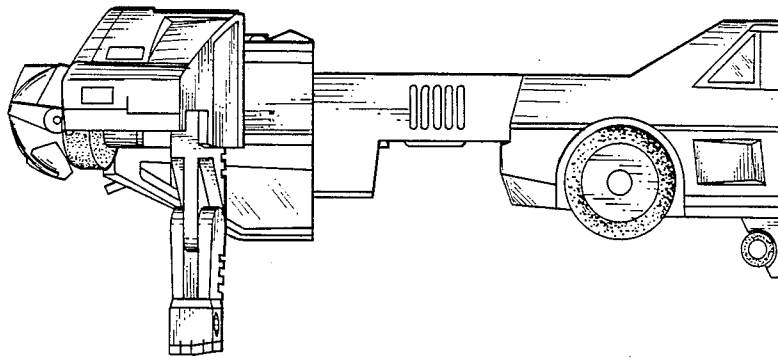

FIG.15



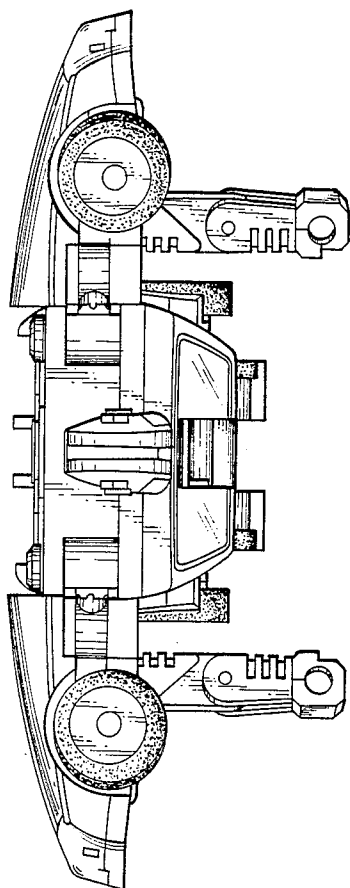

FIG. 17

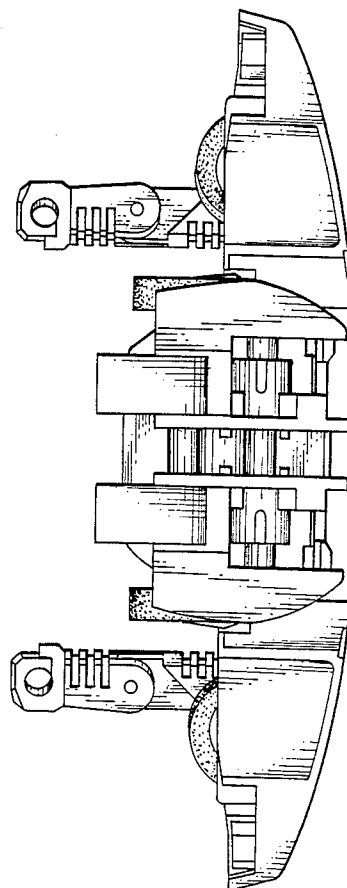

FIG. 18